



UNIVERSITY OF CAMBRIDGE INTERNATIONAL EXAMINATIONS
International General Certificate of Secondary Education

CANDIDATE
NAME

CENTRE
NUMBER

--	--	--	--	--

CANDIDATE
NUMBER

--	--	--	--

* 0 5 8 7 4 8 5 0 2 2 *

DESIGN AND TECHNOLOGY

0445/03

Paper 3 Resistant Materials

October/November 2008

1 hour

Candidates answer on the Question Paper.

No Additional Materials are required.

To be taken together with Paper 1 in one session of 2 hours 15 minutes.

READ THESE INSTRUCTIONS FIRST

Write your Centre number, candidate number and name on all the work you hand in.

Write in blue or black pen.

You may use a soft pencil for any diagrams, graphs or rough working.

Do not use staples, paper clips, highlighters, glue or correction fluid.

DO NOT WRITE IN ANY BARCODES.

Section A

Answer **all** questions in this section.

Section B

Answer **one** question in this section.

You may use a calculator.

The total of the marks for this paper is 50.

The number of marks is given in brackets [] at the end of each question or part question.

For Examiner's Use	
Section A	
Section B	
Total	

This document consists of **16** printed pages.



Section A

Answer all questions in this section.

1 Fig. 1 shows a joint marked out on a piece of solid wood.

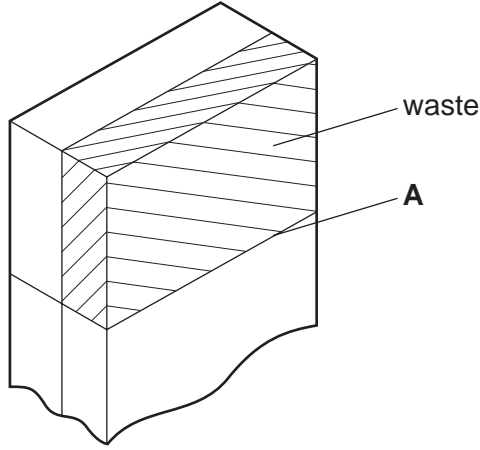

Fig. 1

Name an appropriate tool that you would use to:

(a) mark out the line A;

..... [1]

(b) remove the waste.

..... [1]

2 Complete the table below by stating a method of preventing corrosion of the steel products.

Steel product	Method of preventing corrosion
garden gate	
dustbin	
wire shelves in a fridge	

[3]

3 Fig. 2 shows a fork made by gluing together wood veneers.

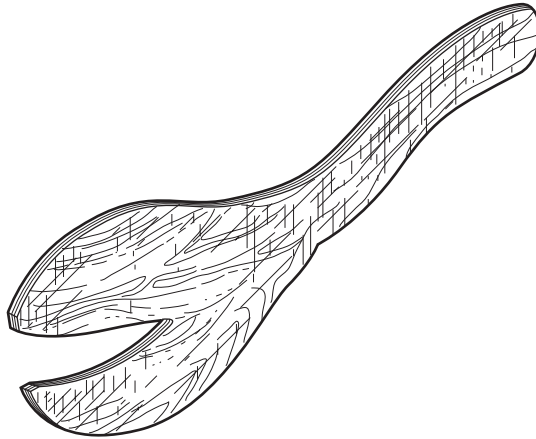

Fig. 2

(a) Name the process used to make the fork.

..... [1]

(b) Give **one** benefit of using this process when making the fork.

..... [1]

4 Describe **two** features of the mould shown below that make it suitable for vacuum forming.

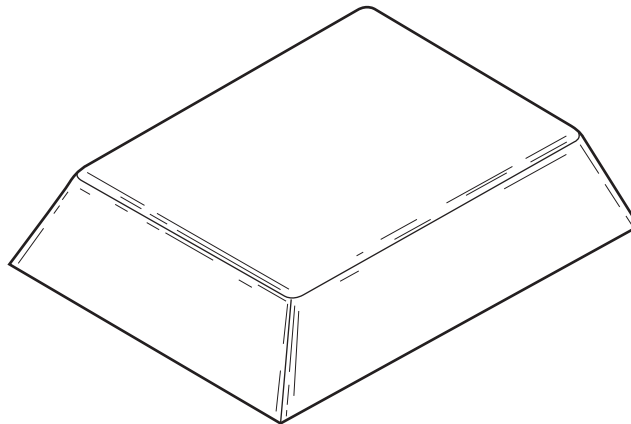

1 [1]

2 [1]

- 5 Fig. 3 shows a hardwood block and a centre marked where a hole will be bored using a brace and a bit.

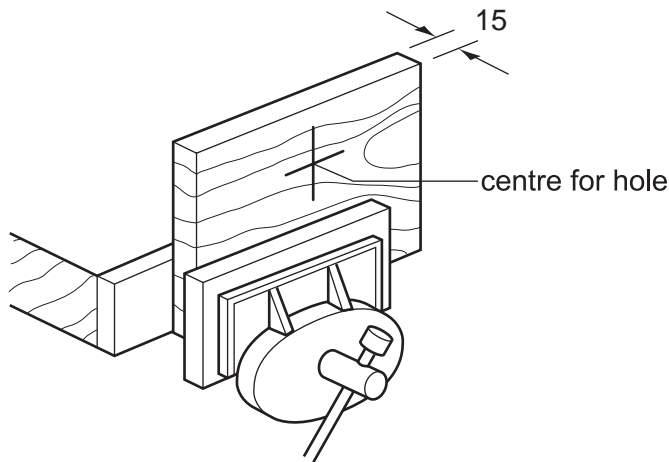

Fig. 3

- (a) State the possible damage to the hardwood that is likely to occur when boring the hole using a brace and bit.

..... [1]

- (b) Describe how the risk of damage could be prevented.

..... [1]

- 6 Complete the sketch below to show a rebate.

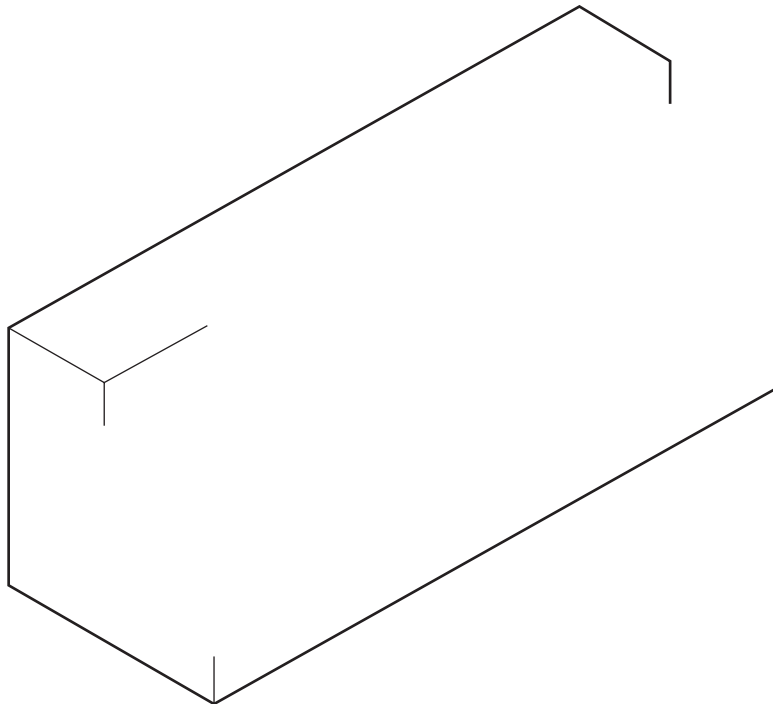

[3]

7 Thermoplastics have a memory. Explain what is meant by the term 'plastic memory'.

.....
.....
..... [2]

8 Explain the purpose of the safe edge on a hand file when filing the shape shown below.

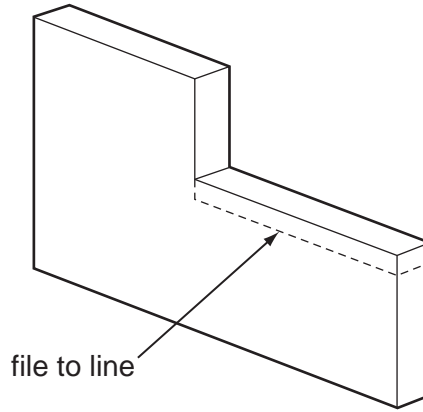

.....
..... [2]

9 (a) State why a piece of copper might need to be annealed.

..... [1]

(b) Describe briefly how you would anneal a piece of copper.

.....
..... [2]

10 Fig. 4 shows a length of wood mounted between centres on a lathe.

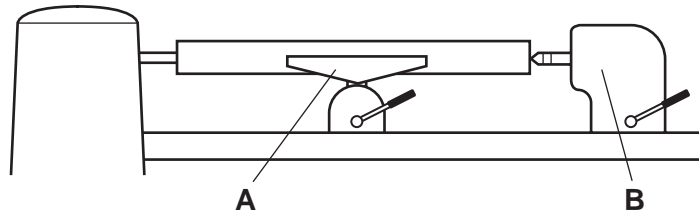

Fig. 4

(a) Name the parts of the lathe A and B.

A [1]

B [1]

(b) Fig. 5 shows a piece of solid wood to be turned between centres on a lathe.

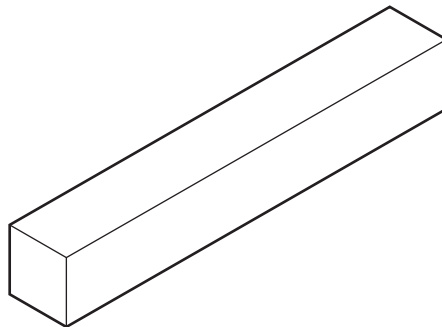

Fig. 5

Describe **two** stages in the preparation of the piece of wood before mounting between centres on the lathe.

1 [1]

2 [1]

Section B

Answer **one** question from this section.

- 11 Fig. 6 shows a game. The object of the game is to locate each of the eight balls in the eight holes. The cover and base are made from acrylic.

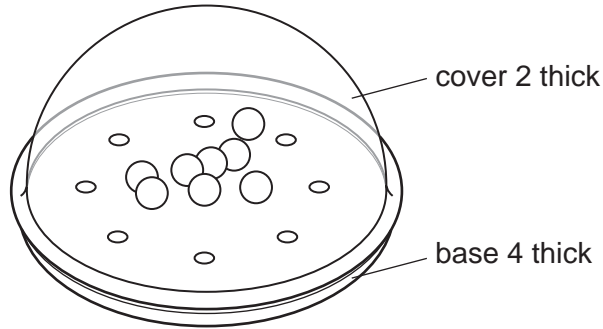

Fig. 6

- (a) Give **three** properties of acrylic that make it suitable for the game.

- 1 [1]
- 2 [1]
- 3 [1]

- (b) Fig. 7 shows the base of the game marked out.

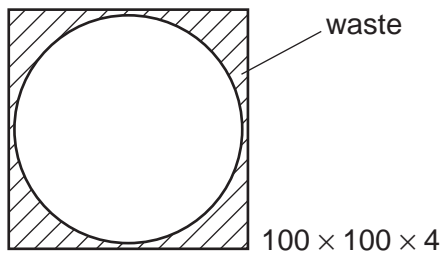

Fig. 7

Name **two** tools used to:

- (i) mark out the shape;

- 1 [1]
- 2 [1]

- (ii) remove the waste to produce the circular shape;

- 1 [1]
- 2 [1]

(iii) finish and polish the edges.

1

2 [1]

(c) The holes in the base will be drilled using a drilling machine.

(i) Explain why the acrylic sheet would need to be clamped down when drilled.

.....

.....

..... [2]

(ii) Use sketches and notes to show how the acrylic sheet would be clamped down.

[2]

(d) Use sketches and notes to describe how the cover would be made by:

(i) vacuum forming;

[4]

(ii) blow moulding.

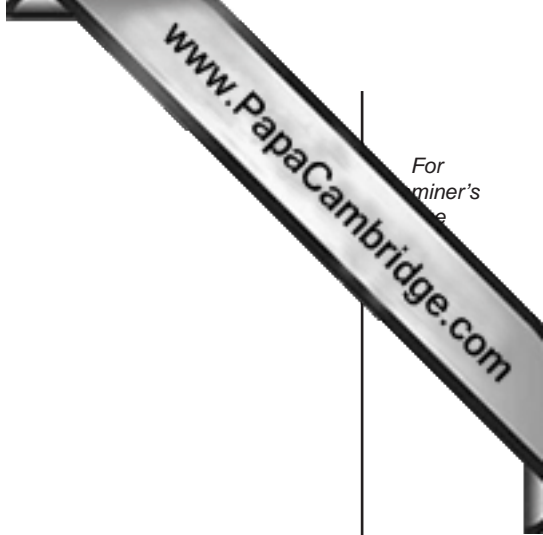

For
miner's
e

[4]

(e) Fig. 8 shows the base and cover.

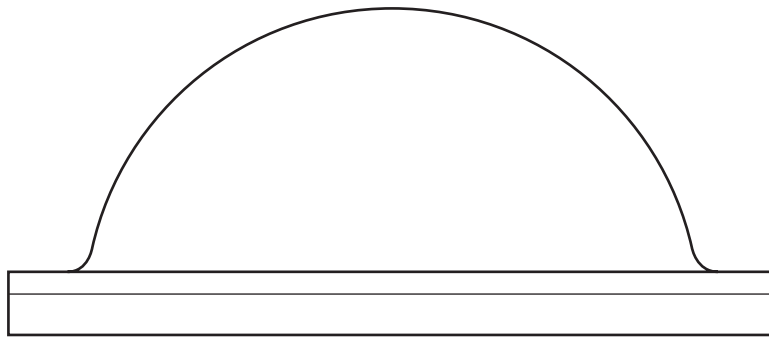

Fig. 8

Use sketches and notes to show how the cover could be joined to the base without an adhesive.

[4]

- 12 Fig. 9 shows a desktop toy that can be made to move by rocking the suspended weight. The desktop toy is made from aluminium except the base which is made from wood.

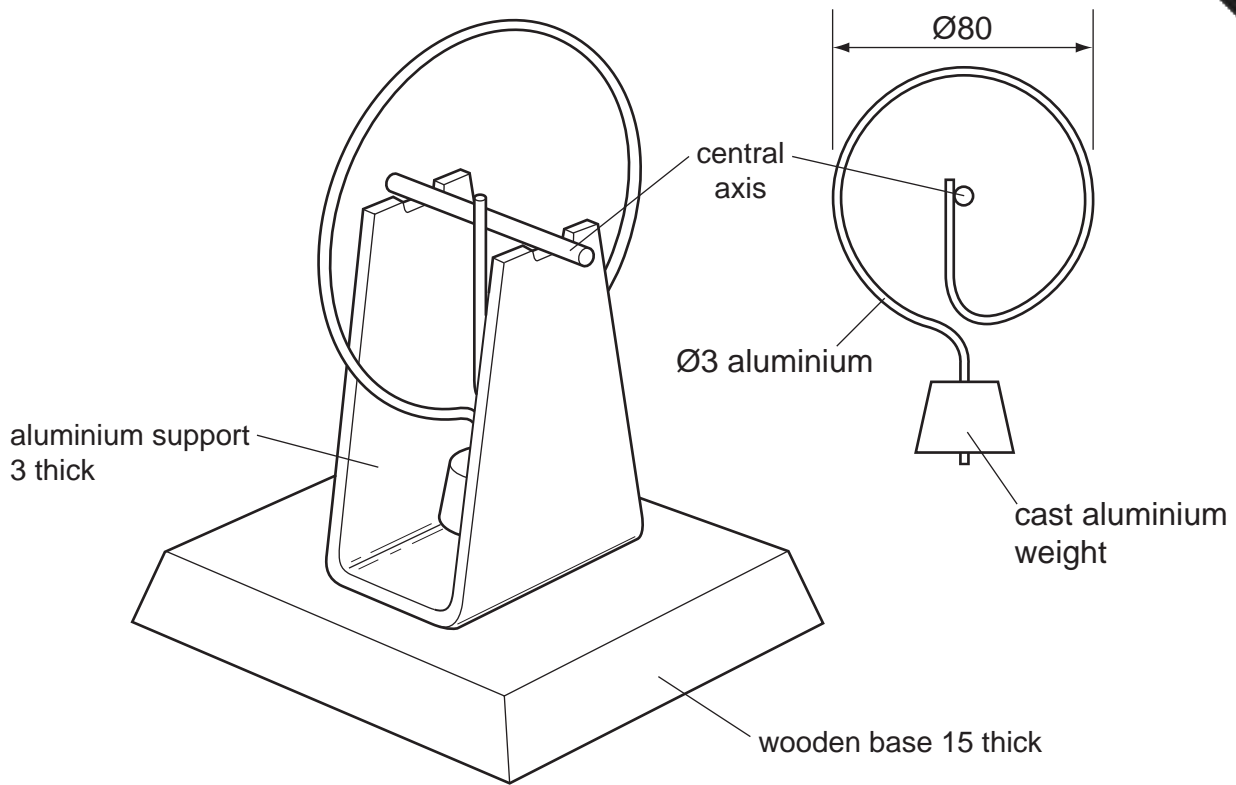

Fig. 9

- (a) Fig. 10 shows details of the aluminium support.

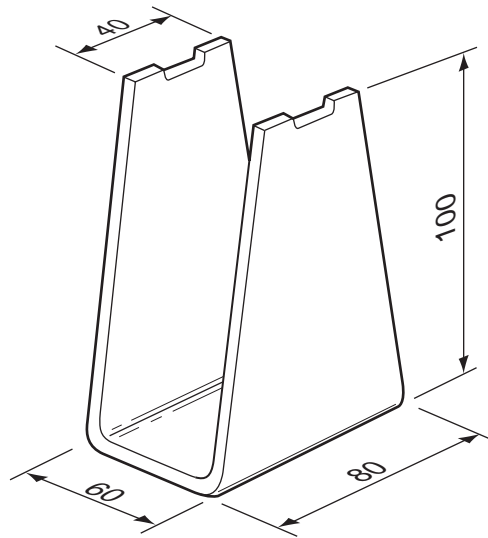

Fig. 10

The aluminium sheet from which the support will be made is shown below.

(i) Mark out the shape of the support accurately on the sheet shown below.



scale 1/2 full size

[3]

(ii) A pencil and a scriber would be used to mark out the lines on the aluminium sheet. Explain why some lines would be marked out using a pencil and why some lines would be marked out using a scriber.

.....
.....
..... [2]

(iii) Name **one** specific saw used to cut off the waste.

..... [1]

(iv) Name **one** specific file used to smooth the sawn edge.

..... [1]

(b) Use sketches and notes to show how the aluminium sheet in (a)(i) could be bent to the shape of the support shown in Fig. 10.

Include the following details:

- the method of holding the aluminium sheet;
- the method of applying the force needed.

[5]



For
miner's
e

(c) The aluminium weight is made by sand casting.

(i) Complete the table below by describing some of the stages in sand casting the aluminium weight.

Sand casting process
make wooden pattern
remove aluminium weight from sand

[4]

(ii) Describe **two** safety precautions you would need to take when sand casting.

1 [1]

2 [1]

(d) Use sketches and notes to show how the aluminium support could be fixed to the wooden base without the use of an adhesive (glue).

[3]

(e) The aluminium parts of the desktop toy would be self-finished.

(i) State what is meant by the term 'self-finished'.

.....
..... [1]

(ii) Describe how a high quality, self-finish would be achieved.

.....
.....
..... [3]

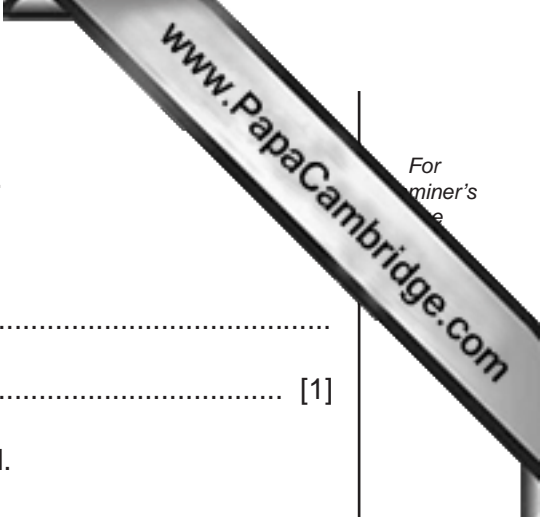

For
miner's
e

13 Fig. 11 shows a bookcase used in a school library. The bookcase will have two glass sliding doors.

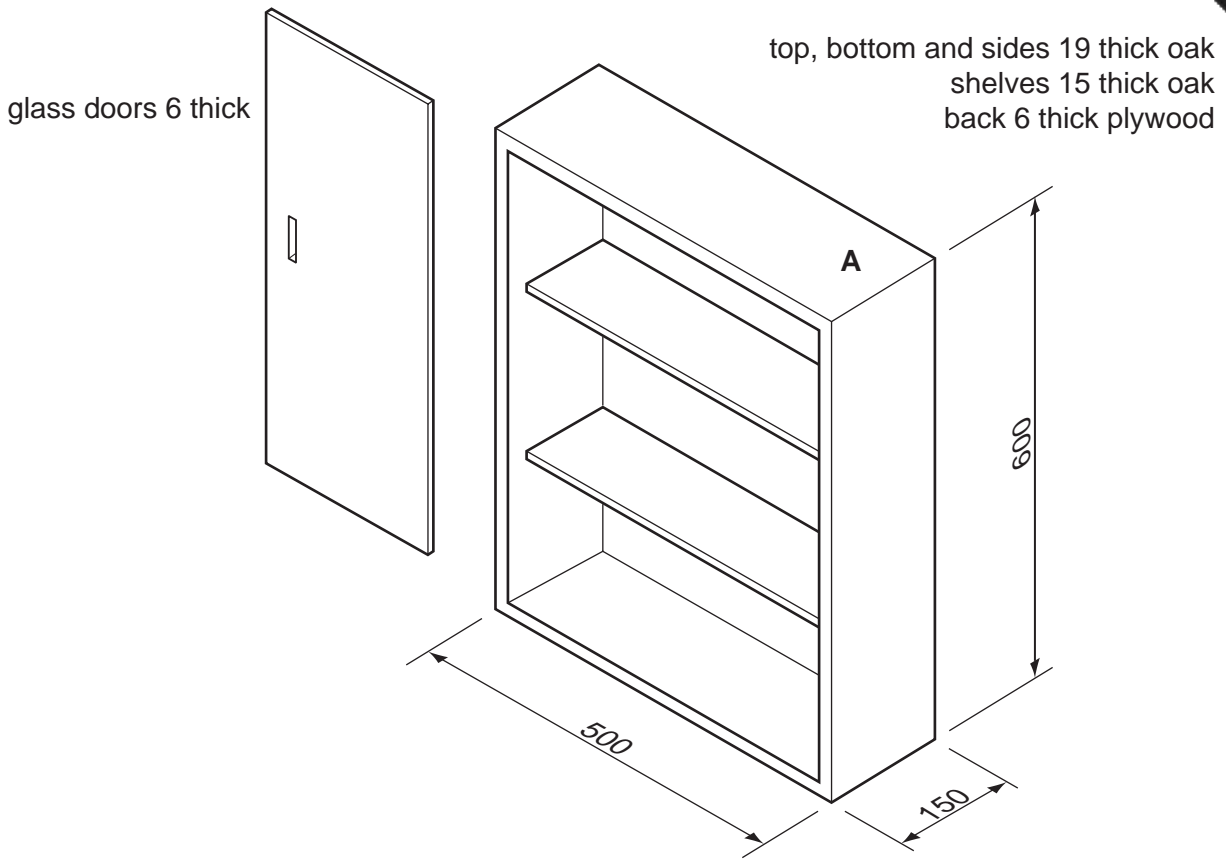
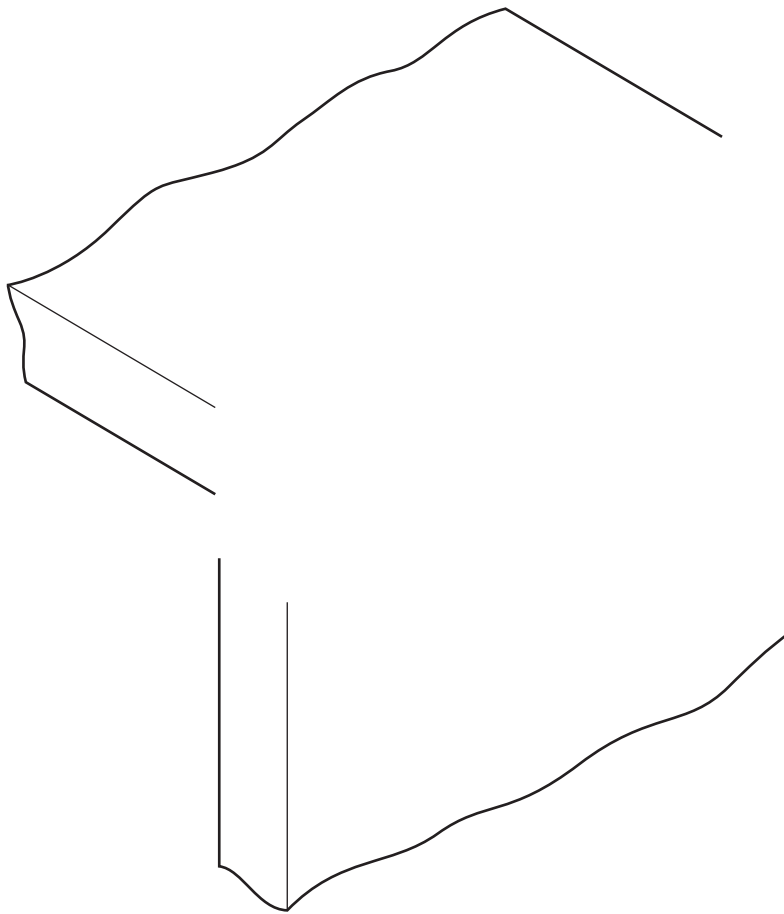

Fig. 11

(a) A cutting list of materials for the bookcase is shown below. Complete the cutting list.

Part	Number required	Sizes			Material
		Length	Width	Thickness	
top and bottom	2	500	150	19	oak
bookcase sides	2	600	150	19	oak
shelves				15	oak
back				6	plywood

(b) (i) Complete the drawing below to show a suitable joint, other than a butt joint, at corner A.



[3]

(ii) Name of joint at corner A.

..... [1]

(c) Both shelves of the bookcase are to be made adjustable. They must be able to be moved 20mm higher or lower than shown in Fig. 11. Use sketches and notes to show how the shelves could be made adjustable. Include details of any materials and/or fittings used.

[5]

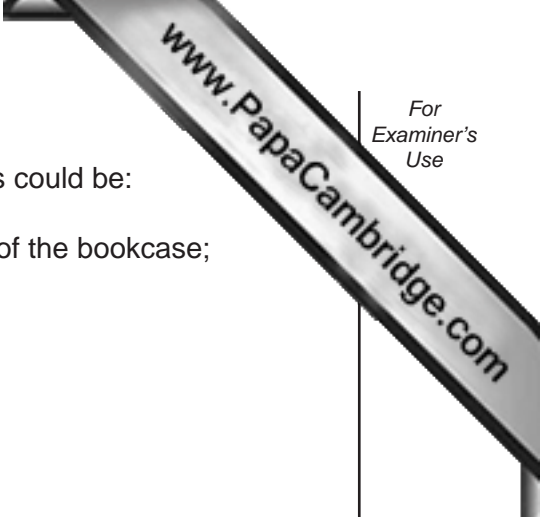

(d) (i) Use sketches and notes to show how the **two** glass doors could be:

- made to slide freely between the top and the bottom of the bookcase;
- removed for cleaning.

[4]

(ii) Some bookcases have hinged doors rather than sliding doors.
Give **one** advantage of using sliding doors.

..... [1]

(e) The bookcase will be finished with two coats of polyurethane varnish.

Complete the table below by giving details of the stages in preparing the surfaces to take the polyurethane varnish and the application of the polyurethane varnish.

Stages
clean the surfaces using a smoothing plane
apply second coat of polyurethane varnish and allow to dry

[5]

Permission to reproduce items where third-party owned material protected by copyright is included has been sought and cleared where possible. Every reasonable effort has been made by the publisher (UCLES) to trace copyright holders, but if any items requiring clearance have unwittingly been included the publisher will be pleased to make amends at the earliest possible opportunity.